



Design and Construction of IoT-Based Smart Wardrobe with RGB Sensor and Sound Sensor

Nugroho Noto Susanto ^{1*}, Doni Setiawan ², Adi Sulisty ³, Aziz Yulianto Pratama ⁴, Nina Faoziah ⁵, Fahmy Ferdian Dalimarta ⁶

^{1*} University of Muhammadiyah Tegal, Indonesia. Email nugrohonotosusanto123@gmail.com

² University of Muhammadiyah Tegal, Indonesia. Email donisukisno@gmail.com

³ University of Muhammadiyah Tegal, Indonesia. Email muhadisulistyo@gmail.com

⁴ University of Muhammadiyah Tegal, Indonesia. Email pratamaaziz08@gmail.com

⁵ University of Muhammadiyah Tegal, Indonesia. Email ninafaoziah@gmail.com

⁶ University of Muhammadiyah Tegal, Indonesia. Email Fahmy@umtegal.ac.id

*Corresponding Autor Email nugrohonotosusanto123@gmail.com

Abstract.

Background. Looking at the technological developments and challenges faced by traditional wardrobe users.

Aim. This research aims to design and build a smart wardrobe based on the Internet of Things (IoT) equipped with color sensors and sound sensors. This cabinet is designed to make it easier for users to organize and find the clothes they want with the help of advanced technology.

Methods. The color sensor will detect the color of the garment and allow the system to suggest a combination of garments that suit the user's preferences. Meanwhile, the voice sensor allows for control of the wardrobe through voice commands, providing convenience for users to access clothes without having to open the closet door manually. This smart cabinet uses microcontroller-based hardware connected to a mobile app to manage and monitor the status of cabinets. The integrated IoT system allows the cabinet to function automatically and respond quickly to the input received from the sensors.

Result. The results of this research are expected to produce more efficient devices for organizing and searching for clothes, as well as provide a more interactive and practical user experience. In addition, by optimizing IoT technology,

Implication. This research aims to introduce a more sophisticated smart home concept, with a wardrobe as one of the elements that support the ease of daily life.

Keywords: Arduino, Sound sensor, Color sensor, IoT, RGB sensor

INTRODUCTION

Current technological developments have had a significant impact on various aspects of life, including the management and utilization of space at home (Feriyanti et al., 2022). One of the important elements in daily life is the wardrobe, which serves to store and organize clothes (Pratama & Setiawan, 2024). However, in many cases, traditional wardrobes often cannot provide convenience for their users to find clothes quickly, especially in poor lighting conditions or when clothes are not well organized (Sudirman et al, 2020).

On the other hand, Internet of Things (IoT) technology provides a great opportunity to change the way we interact with household devices (Pratama et al, 2023). IoT allows devices to connect and communicate, which opens up opportunities for developing intelligent and automated systems (Madakam et al, 2025). In the context of wardrobes, IoT can be applied to improve the efficiency of organizing clothes and make it easier to find desired items (Gokhale et al, 2018).

One solution that can be integrated into a wardrobe is the use of RGB sensors, which can automatically detect the color of clothes (Faria et al., 2017). With this technology, the system can recognize and classify the color of clothes in the closet (Zafeiriou, 2020), making it easier for users to choose clothes that match their color preferences without having to open and check each piece of clothing individually (Pratama et al, 2024). Additionally, the use of sound sensors allows for easier and more practical interaction with wardrobes (Ningtias et al, 2024). With the integrated sound sensor, users can give voice commands to open the closet, search for clothes by specific categories or colors, and even set the lighting system inside the closet. This technology supports a more hands-free experience, increasing comfort and efficiency (Kamal, 2024).

This research aims to design and build IoT-based smart wardrobes equipped with RGB sensors and sound sensors. With the integration of this technology, it is hoped that smart wardrobes can provide more practical, efficient, and intelligent solutions in managing clothes and provide a better user experience in daily life.

METHODS

In the preparation of this Final Project Report, the author uses several research methods, including:

1. Preparation

Contains the selection of materials and journals that will be used as a basis or literature in the manufacture of IoT-Based Smart Wardrobes with Sound Sensors and Sensors

2. Observation

Carrying out research and observation at the house of Mr. Irvan Saputra as my boss in Jakarta

3. Consultation

Consult with parties who can help prepare the Final Project report.

4. Tool Testing

testing on the tool that has been created.

5. Evaluation and Drawing of Conclusions

The evaluation is carried out to find out whether the tool is working as planned and draw conclusions from the evaluation.

LITERATURE REVIEW

IoT (Internet of Things)

The Internet of Things (IoT) is a major interest as a result of technology development and the Industrial Revolution 4.0. IoT applications have been widely implemented in every sector, including security systems, monitoring, industry, agriculture, and medicine. Several studies have developed IoT-based smart homes, such as home security systems, using the internet. Previously, the development of IoT in the health sector has been carried out, one of which is in the journal *Development of Smart Infusion Control and Monitoring System (SICoMS) Based Web and Android Application*, this research aims to develop an automatic infusion system, a tool that can monitor the condition of the infusion volume and monitor the condition of drips carried out remotely using web technology and android applications (Widho Ralenza Pratama, et al., 2022).

Wardrobe

A closet is one of the essential pieces of furniture to be used as a place to store clothes. Currently, there are many choices of types of cabinets with different functions. Originating in the Middle Ages in England, initially this wardrobe originated from a small chest used to store clothes in the castle or royal palace room.

Initially, a wardrobe was a locker that was installed on the wall to be used as a dressing room and clothing storage room. Sometimes it is used to store other items such as jewelry, feathers and spices. Over time, the locker has turned into a modern self-contained wardrobe with a variety of attractive shelves and a space for hanging clothes.

In the early seventeenth century, wardrobes began to be made and formed modernly as part of wooden furniture for clothing storage. And in the nineteenth century, wardrobes began to be formed with additional space to hang clothes on each side and additional mirrors attached as a complement to the decorations. With the development of technology, access between countries has become very easy, now we can see cabinets in various shapes, functions and high-value beauty (Dudhe et al, 2017).



Figure 1. Wardrobe

Arduino Uno R3

The microcontroller consists of the basic components in the form of CPU (Central Processing Unit), RAM (Random Access Memory), ROM (Read Only Memory), in (input) and output (output) ports, as well as USB (Universal Serial Bus) controller, and ADC (Analog

to Digital Converter) controller on certain microcontrollers. The microcontroller works with the basic principle of starting the work by taking data on the ROM with the address on the counter program (PC) and adding (increment) automatically.

Microcontrollers are divided into several groups, namely: (1) Microcomputer Architecture, (2) 8051 Family, (3) PIC Family, (4) AVR Family, and (5) Arduino [6]. Each group of microcontrollers has its own disadvantages and advantages

Arduino is an open source prototyping platform. In its application, Arduino can use hardware and software that are easy to use. In recent years, microcontrollers have been widely used in the creation of automated tools. bMicrocontrollers can also be applied with sensor components that can provide input data to the microcontroller. Therefore, a description related to the application of sensors in microcontrollers is absolutely necessary. (*Anantajaya, I. M. R. A., Kumara, I. N. S., Divayana, Y, 2021*)



Figure 2 Arduino uno R3

Motor Servo

A servo motor is a rotary actuator or a device called a motor, which is designed using a closed-loop feedback control system called a servo. So that it can be set or set-up in determining and ensuring from the angle of the motor output shaft. The servo motor itself consists of a DC motor, gears, a control circuit, and a potentiometer. A series of gears attached to the shaft of the DC motor then slow down the rotation of the shaft and increase the torque of the servo motor, then the potentiometer undergoes a change in its resistance when the DC motor rotates to determine the limit of the rotation position of the servo motor

shaft. The use of a closed-loop control system on servo motors is useful for controlling the movement and final position of the shaft. Servo motors have two types, namely DC and AC servo motors. DC servo motors are usually used in smaller applications such as prototypes. Meanwhile, AC servo motors are used to handle high currents or heavier loads, which are usually often applied to industrial machines. There are two types of servo motors on the market, namely 180° rotation servo motors and continuous rotation servo motors, and they have differences according to rotation in general.

1. The standard servo motor servo rotation 180° is the most common type of servo motor, whose output shaft rotation is limited to only 90° to the right and 90° to the left. The total rotation of the shaft is only a semicircle or 180°.
2. A continuous rotation servo motor is almost the same as a standard servo type, but the rotation of the shaft can rotate continuously or in other words indefinitely, either in the left or right direction. (AR. Wiguna, 2020)



Figure 3. Motor Servo

Arduino Microcontroller

Gears or Gears are driving components and parts of a rotating engine that are useful for transmitting power. Gears have teeth that intersect with the teeth of other gears. Two or more gears that intersect and work together are referred to as gear transmissions, and can generate mechanical gains through the ratio of the number of gears.

Gears are able to change the speed, rotation, torque, and direction of power relative to the power source. Not all gears are related to other gears, one case is a pair of gears and pinions that originate from or produce a translation force instead of rotation. *PT. Indonesia*

Sejahtera, 2023).



Figure 4 Gear

TCS3200 Color Sensor

TCS3200 color sensor is a sensor that is programmed to convert the color of light into a frequency value. This sensor produces an output in the form of a box wave (50% duty cycle) with a frequency that is directly proportional to the light intensity (irradiance) (Madahan et al, 2025). TCS3200 sensor is used to detect and measure the color of an object. This sensor is capable of detecting different types of colors based on wavelength. *(Meranti Nainggolan, Joni Eka Candra, 2023)*



Figure 5 TCS3200 Color Sensor

Voice Recognition Module V3

ELECHOUSE's Version 3 Speech Recognition Module is a compact and easy-to-control speech recognition board. This product is a speaker-dependent speech recognition module. It supports up to 80 voice commands in total. A maximum of 7 voice commands can work simultaneously. Any sound can be trained as a command. Its use requires training the module first before letting it recognize any voice commands. The board has 2 ways of control: Serial Port (full function) and General Input Pin (part of function). Common Output Pins on board can generate several types of waves while voice commands are appropriate.



Figure 6 *Voice Recognition Module V3*

LED (Light Emitting Diode)

A light-emitting diode (LED) is an electronic component that can emit monochromatic light when subjected to an advanced voltage. LEDs still belong to the Diode family. LEDs consist of a chip of semiconductor material that is filled with impurities to create a structure. The color of the light emitted by LEDs depends on the type of semiconductor material they use. LEDs are also able to emit an infrared beam that is invisible to the eye. An example of a TV remote control is one of the electronics that uses LEDs with infrared light (Robby Yuli Endra et al., 2018). The shape of an LED is almost the same as a small bulb and can be easily installed into an electronic device. LEDs with incandescent lamps are very different, LEDs do not require filament burning so they do not generate heat when emitting light. The following are the images and symbols of the LEDs:



Figure 7 LED

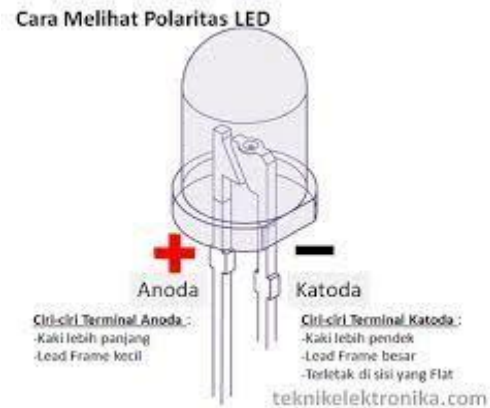

Figure 8 Polarity LED

To determine the polarity of the anode (positive) and cathode (negative) terminals on the LED. We can find out by looking physically based on the image above. The characteristics of the anode terminals and cathodes on LEDs are:

1. The terminal legs of the anode are longer and the cathode is shorter.
2. The anode lead frame is smaller and the cathode lead frame is larger.
3. The cathode is on the flat side. (AR Wiguna)

12V Adapter

An adapter is an electronic device that has 2 functions where it can convert AC voltage (*Alternating Current*) to DC voltage (*Direct Current*) and function as a voltage reducer from high voltage to low voltage. The adapter can lower the voltage from 220 volts AC to a low voltage of 3 volts to 12 volts DC. The *step-down adapter* basically uses a magnetic field induction technique, the main component is the email wire which is wound on the iron core, there are 2 windings, namely the primary winding and the secondary winding, when electricity enters the primary winding there will be induction on the email wire so that there will be a magnetic field force on the iron core then it will induce a secondary winding (Widho Ralenza Pratama, et al., 2022).



Figure 9 12v Adapter

Block Diagram Design

Block diagrams are very important diagrams in system design, because they are simple representations of the entire system that is created. In this design, it is broadly divided into several parts, namely the Arduino uno R3 as a microcontroller and a place to store data, as well as as the core of the circuit that connects hardware such as sound sensors, color sensors and servo motors.

Block Diagram Workflow:

1. The adapter will send power to the Arduino
2. The voice sensor will perform the process of identifying incoming sounds
3. The color sensor will identify the color according to the input obtained from the sound sensor
4. The identification results will activate the servo motor and move the gear.
5. The gear will move according to the identification results and display the clothes you are looking for.

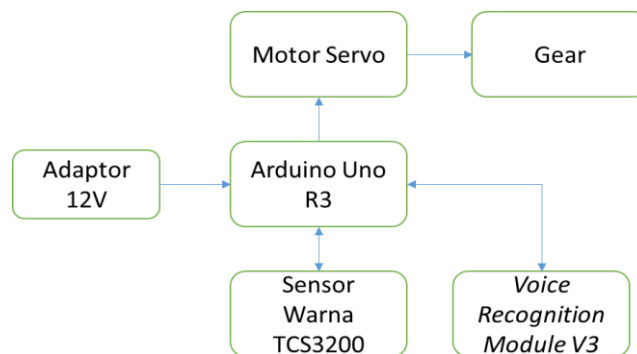

Figure 10. Smart cabinet block diagram

Flow Diagram

Flowcharts are made to make it easier to understand the course of the system that we create in general. The existence of *a flowchart* will help in depicting the course of a system, process, inputs used, and *outputs* that will occur.

1. The appliance is switched on by connecting a 12v adapter
2. LED and Arduino active with standby state
3. Sound sensor picks up incoming sound from the microphone
4. The color sensor identifies the color according to the sound sensor results
5. Once the color has been identified, the gear will rotate to display the clothes with the color you are looking for.
6. The appliance will always be on standby until the appliance is switched off.

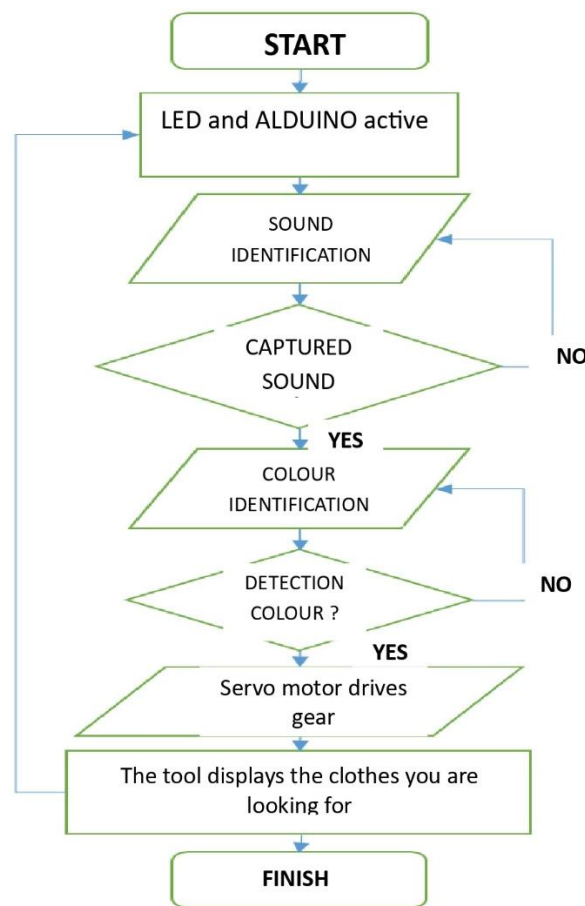

Figure 11. Flowchart

DISCUSSION

System Test Results

RGB Sensor (Clothing Color Detection):

1. **Color Detection Performance:** The RGB sensor used is able to detect the color of clothes with a fairly good level of accuracy. Clothes that have a light dominant color can be clearly recognized, but clothes with darker colors or have color variations may be a little difficult to recognize. Some of the more complex color variations, such as gradations or complex patterns, require further adjustments in the color processing algorithm.
2. **Detection Speed:** The color detection process is quite fast, but for clothes that overlap or are too close, the accuracy of the sensor decreases. This indicates that the arrangement of the clothes in the closet must be done carefully so that the sensor can work optimally.
3. **Limitations:** RGB sensors sometimes struggle in very low or overexposed lighting conditions, which can affect the quality of color detection.

Voice Sensor (Voice Command Recognition):

1. **Speech Recognition Accuracy:** The voice sensor (microphone) can pick up voice commands well in quiet room conditions. However, in environments with a lot of noise, voice recognition tends to experience a decrease in accuracy. The voice recognition system can recognize basic commands such as "Open closet," "Look for red clothes," and "Close closet" with a high success rate.
2. **System Response to Voice Commands:** Once a voice command is recognized, the system is able to respond quickly and take appropriate action. For example, when the "Search for red clothes" command is given, the system will check the color of the clothing detected by the RGB sensor and display information related to the corresponding clothing.
3. **Limitations:** More complex or unclear voice commands are sometimes not perfectly recognized. Improvements to speech recognition algorithms or the addition of voice

command correction features could be a solution to this problem.

Microcontrollers and IoT Integration:

1. **Microcontroller Performance:** Microcontrollers (such as Arduino or ESP32) used to control RGB sensors and sound sensors work well, connecting hardware with IoT applications effectively. Data processing from RGB and sound sensors can be done smoothly, and the microcontroller successfully transmits data to the user's device via a Wi-Fi or Bluetooth connection.
2. **System Stability:** The built system is stable, with little interference in communication between hardware and software. The data communication process between the microcontroller and the mobile application runs smoothly without significant interruptions.

IoT (User Interface) Applications:

1. **Ease of Use of the App:** A mobile app designed to control a smart wardrobe runs well. Users can easily give voice commands or access clothing-related information through the app's interface. The intuitive navigation makes using the app easy for users.
2. **Real-Time Data Update:** The app can update the status of the wardrobe in real-time, allowing users to find out information about the clothes in the closet.

Result Analysis

Excess:

1. **Ease of Use:** Users can control the smart wardrobe through voice commands or apps, which makes the system very user-friendly, especially for users who are looking for ease of interaction without having to open the closet manually.
2. **Organizing Efficiency:** This system can assist users in organizing clothes based on predefined colors and categories, which makes it easier to search for clothes.
3. **IoT integration:** The use of IoT technology allows cabinets to connect with other devices and be accessed remotely, providing convenience for users who want digital control over their wardrobe.

Deficiency:

1. **Dependence on Lighting:** RGB sensors are still affected by ambient lighting conditions.

Clothes that are poorly or excessively exposed can affect the accuracy of color detection.

2. **Speech Recognition Accuracy:** Speech recognition systems can be disrupted in noisy environments, which reduces the effectiveness of the voice commands given.
3. **Limitations of Overlap Clothing Detection:** If clothes are placed too tightly or overlapping, RGB sensors can have difficulty detecting colors precisely, so the system needs to be equipped with more sophisticated algorithms to handle these cases.

Development Potential:

1. **Improved Color Processing Algorithms:** The development of more complex algorithms can improve the accuracy of color detection, especially on garments with intricate color patterns or gradations.
2. **Improved Voice Recognition with Machine Learning:** By using machine learning technology, voice recognition can be improved, so that the system can be more accurate in recognizing voice commands in noisy conditions.
3. **Integration with Smart Home Systems:** This smart wardrobe can be further developed by integrating its system into a broader smart home ecosystem, allowing users to control various devices in the home through a single app or voice command.

CONCLUSION

The design and construction of IoT-based smart wardrobes with RGB sensors and sound sensors has succeeded in creating a system that can improve the efficiency, convenience, and interaction of users with everyday household devices. Based on the test results, this system provides various benefits and conveniences, including:

1. **Ease in Clothes Search:** The RGB sensor allows the wardrobe to automatically detect the color of the clothes, making it easier for users to find the clothes they want without having to open the wardrobe one by one. Users can more quickly determine the clothes that match their color preferences.
2. **Hands-Free Interaction with Sound Sensors:** Voice sensor integration allows for control of cabinets through voice commands, so users no longer need to physically open

cabinets. This system provides more convenience, especially for users who have physical limitations or who want a hands-free experience.

3. **Application of IoT Technology:** The use of IoT allows smart wardrobes to connect with mobile apps and other devices, providing remote control and real-time data updates. This makes smart wardrobes part of a wider smart home system, which can make household management easier.
4. **Potential for Development:** While the system has worked well, there is potential to improve color detection accuracy, especially in garments that have more complex patterns or colors. Additionally, speech recognition can be further improved by using machine learning algorithms to improve accuracy in noisy environments.

BIBLIOGRAPHY

- Bhadoria, R. K., Saha, J., Biswas, S., & Chowdhury, C. (2021). IoT-based location-aware smart healthcare framework with user mobility support in normal and emergency scenario: a comprehensive survey. *Healthcare Paradigms in the Internet of Things Ecosystem*, 137-161.
- Diraco, G., Rescio, G., Siciliano, P., & Leone, A. (2023). Review on human action recognition in smart living: Sensing technology, multimodality, real-time processing, interoperability, and resource-constrained processing. *Sensors*, 23(11), 5281.
- Dudhe, P. V., Kadam, N. V., Hushangabade, R. M., & Deshmukh, M. S. (2017, August). Internet of Things (IOT): An overview and its applications. In *2017 International conference on energy, communication, data analytics and soft computing (ICECDS)* (pp. 2650-2653). IEEE.
- Faria, R., Brito, L., Baras, K., & Silva, J. (2017, July). Smart mobility: A survey. In *2017 International conference on internet of things for the global community (IoTGC)* (pp. 1-8). IEEE.
- Feriyanti, R. V., Pratama, A. Y., & Novianto, D. (2022). Analysis of Temperature Monitoring System with LM35 Sensor Using OHP (Over Head Projector) Based on Raspberry Pi. *Journal of Applied Electrical Engineering*, 6(2), 43-47.
- Gokhale, P., Bhat, O., & Bhat, S. (2018). Introduction to IOT. *International Advanced Research Journal in Science, Engineering and Technology*, 5(1), 41-44.
- Kamal, M. A. (2024). *Implementation of fuzzy mamdani logic on a prototype of a residential flood early handling system using an internet of things device* (Bachelor's thesis, Faculty of Science and Technology UIN Syarif Hidayatullah Jakarta).
- Kothari, S. M., Khedkar, V. N., Jadhav, R., & Bawiskar, M. (2023). Analysis of RGB Depth Sensors on Fashion Dataset for Virtual Trial Room Implementation. *Research Trends in Artificial Intelligence: Internet of Things*, 203.

- Madakam, S., Ramaswamy, R., & Tripathi, S. (2015). Internet of Things (IoT): A literature review. *Journal of Computer and Communications*, 3(5), 164-173.
- Meshram, V. V., Patil, K. R., Meshram, V. A., & Bhatlawande, S. (2022). SmartMedBox: A smart medicine box for visually impaired people using IoT and computer vision techniques. *Revue d'Intelligence Artificielle*, 36(5), 681.
- Ningtias, D. W. A., Pratama, A. Y., Usman, D., & Humaidi, H. N. A. (2024). Analysis Of Lighting Standards, A Case Study Of The Electrical Technology Building Of The Indorama Engineering Polytechnic. *Ramatekno*, 4(2), 34-43.
- Petrushin, A., Freddolini, M., Barresi, G., Bustreo, M., Laffranchi, M., Del Bue, A., & De Michieli, L. (2022). IoT-powered monitoring systems for geriatric healthcare: overview. *Internet of Things for Human-Centered Design: Application to Elderly Healthcare*, 99-122.
- Ponnusamy, S., Bora, V., Daigavane, P. M., & Wazalwar, S. S. (Eds.). (2024). *Wearable Devices, Surveillance Systems, and AI for Women's Wellbeing*. IGI Global.
- Prakasa, F. B. P., & Maiga, J. (2019, March). Iot-based smart and healthy wardrobe system. In *2019 International Conference of Artificial Intelligence and Information Technology (ICAIIIT)* (pp. 119-123). IEEE.
- Pratama, A. Y., & Setiawan, D. (2024). THE TRAINING OF TEMPERATURE MONITORING SYSTEM WITH LM35 SENSOR BASED ON RESBEERY PI. *Jurnal Abdisci*, 1(12), 455-462.
- Pratama, A. Y., Asry, D. W., Usman, D., Asmoro, P. T., & Siswoyo, F. (2024). The Power Factor Optimization with Cos Phi Mode Trainee. *Journal of Improsci*, 2(2), 95-109.
- Pratama, A. Y., Prasetijo, A. B., & Sofwan, A. (2023). Evaluation of the performance of broadcast vehicular ad hoc network (vanet) routing. *Technomedia Journal*, 8(2 Special Issues), 236-247.
- Sharma, A., Misra, A., Subramaniam, V., & Lee, Y. (2019, November). SmrtFridge: IoT-based, user interaction-driven food item & quantity sensing. In *Proceedings of the 17th Conference on Embedded Networked Sensor Systems* (pp. 245-257).
- Sudirman, S., Wulan, N., Ramadhani, S. F., Tanniewa, A. M., Pratama, A. Y., Akram, R., ... & Alfath, I. (2024). *Information Technology Basics for Beginners*. Our Writing Foundation.
- Zafeiriou, I. (2020, October). IoT and mobility in smart cities. In *2020, 3rd World Symposium on Communication Engineering (WSCE)* (pp. 91-95). IEEE.